

### 执行标准 Implementation Standards

结构长度 Structure length GB1221-89

法兰标准 Flange standard JB79-59

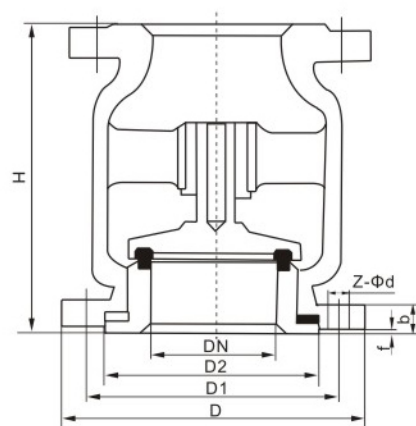

### 主要性能规范 Main Performance Specification

试验压力 Test pressure(MPa)	公称压力 PN (MPa)		
	1.6	2.5	4.0
壳体强度试验 Shell strength test	2.4	3.75	6.0
密封试验(液) Seal test (liquid)	1.76	2.75	4.4
密封试验(气) Seal test (gas)	0.5~0.7	0.5~0.7	0.5~0.7
适用介质 Applicable medium	C 水、蒸汽、油品 Water, steam, oil	P 硝酸类 Nitric acid	R 油品 oil
适用温度 Applicable temperature	≤425°C	≤100°C	≤550°C

### 主要外形尺寸 Main Dimension

DN	H	D	D1	D2	B	F	Z-Φd
<b>PN1.6MPa</b>							
32	145	135	100	78	18	2	4-18
40	160	145	110	85	18	3	4-18
50	170	160	125	100	20	3	4-18
65	180	180	145	120	22	3	4-18
80	200	195	160	135	22	3	8-18
100	220	215	180	155	24	3	8-18
125	270	245	210	185	28	3	8-18
150	300	280	240	210	30	3	8-18
200	390	335	295	265	34	3	12-23